

HW SERIES



HW SERIES

Digital RH & RH/T Thermistor/RTD/Temp Transmitter (Non-Display Model)

Installer's Specifications

HS Element	Digitally profiled thin-film capacitive (32 bit mathematics) U.S. Patent 5,844,138
Accuracy at 25°C from 10-80% RH**	Multi-point calibration; NIST traceable ±2%, 3%, or 5% models ±1% at 12-60% RH in voltage output mode ±1% at 20-40% RH in mA output mode ±1% at 12-60% RH in mA output mode with temp transmitter
Reset Rate*	24 hours
Stability	±1%@20°C (68°F) annually, for two years
Hysteresis	1.5% (typical)
Linearity	Included in Accuracy spec.
Operating Humidity Range	0 to 100% RH
Operating Temperature Range	10°C to 35°C (50°F to 95°F)
Temperature Coefficient	±0.1% RH/°C above or below 25°C (typical)
Analog Output	4-20 mA mode: 2-wire, polarity insensitive 0-5V/0-10 V mode: 3-wire, observe polarity
Scaling	0-100% RH
Input Power	4-20 mA mode: loop powered 12-30 VDC only, 30 mA max. 0-5V/0-10 V mode: 12-30 VDC/24 VAC, 15 mA max.

Optional Temperature Output:

Transmitter Models	Digital, 4-20mA/0-5/0-10V output, accuracy ±0.5°C (±0.9°F) typical
RTD Models	Customer specified thermistor or RTD

NOTICE

- This product is not intended for life or safety applications.
- Do not install this product in hazardous or classified locations.
- Read and understand the instructions before installing this product.
- Turn off all power supplying equipment before working on it.
- The installer is responsible for conformance to all applicable codes.

DIMENSIONS

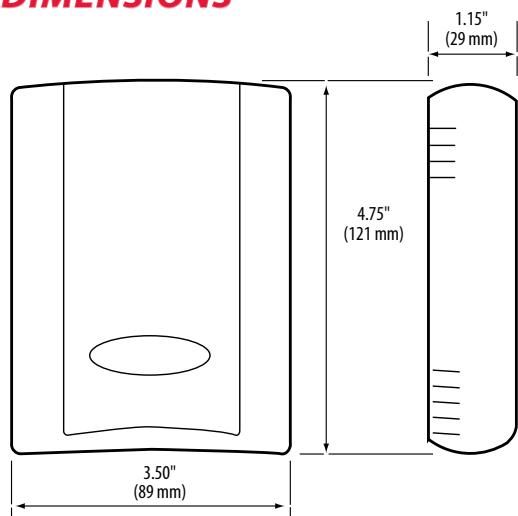

EMC Conformance: EN61000-6-3:2007 and A1:2011, EN61000-6-1:2007

One side of transformer secondary is connected to signal common. Isolation transformer or dedicated power supply may be required. To conform to EMC standards, shielded cabling and technical information is available from the factory upon request or is available on our website: www.veris.com

* Reset Rate is the time required to recover to 50% RH after exposure to 90% RH for 24 hours.

** Specified accuracy with 24 VDC supplied power with rising humidity.

RTD/Thermistors in wall packages are not compensated for internal heating of product.

QUICK INSTALL

1. Mount the sensor on a vertical wall, about 4½ feet above the floor, in a location away from ventilation sources.
2. Affix the backplate to the wall.
3. Wire the device. Refer to wiring diagrams on page 2.
4. Install the cover.

PRODUCT IDENTIFICATION

Display	Accuracy	NIST	US or EU	Temp.
HW <input checked="" type="checkbox"/>	<input type="checkbox"/>	<input type="checkbox"/>	<input type="checkbox"/>	<input type="checkbox"/>
= No display	1 = 1% 2 = 2% 3 = 3% 5 = 5%	N = NIST X = No	S = Standard C = CE	T = Temp X = No Temp (Stop here)

Sensor Type	Temp. Cal. Cert.	Option	Value
<input type="checkbox"/>	<input type="checkbox"/>	<input type="checkbox"/>	<input type="checkbox"/>
A = Transmitter: 10°-35°C (50°-95°F) or 0°-50°C (32°-122°F) (switchable) B = 100R Platinum, RTD C = 1k Platinum, RTD D = 10k T2, Thermistor E = 2.2k, Thermistor F = 3k, Thermistor G = 10k CPC, Thermistor H = 10k T3, Thermistor J = 10k Dale, Thermistor	X = No Cert. 1 = 1 pt cal. 2 = 2 pt cal.	1 = Pushbutton Override 2 = Setpoint Slider 3 = Pushbutton Override and Setpoint Slider	A = 1k F = 10k G = 20k K = 50k M = 100k
K = 10k with 11k shunt, Thermistor M = 20k NTC, Thermistor N = 1800 ohm TAC, Thermistor R = 10k US, Thermistor S = 10k 3A 221, Thermistor T = 100k, Thermistor U = 20k, "D" Thermistor W = 10k T2 high accuracy, Thermistor Y = 10k T3 high accuracy, Thermistor Z = 10k E1, Thermistor			

INSTALLATION



Observe precautions for handling static sensitive devices to avoid damage to the circuitry that is not covered under the factory warranty.

1. Locate the tab at the top of the sensor housing. Using only the minimum required force, press this tab down and pull the cover outward from the top. Set the cover aside.

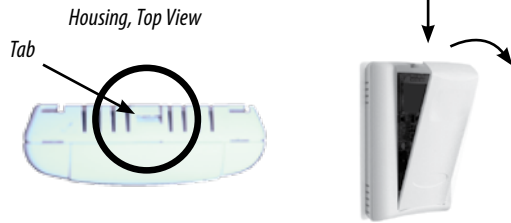

2. Remove the backplate by unfastening the sensor from the bottom of the backplate and pivoting the sensor outward.

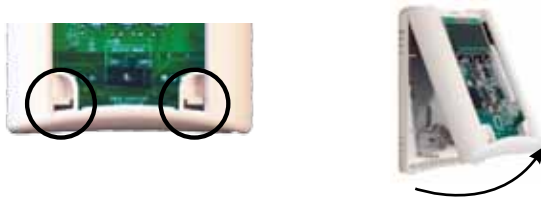

3. Punch out wire opening in the backplate.

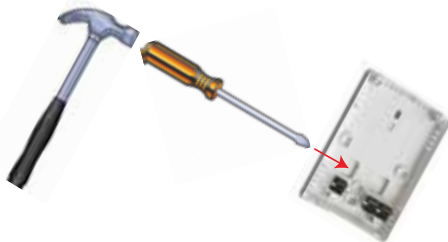

4. Position the backplate vertically on the wall, 4 1/2 feet above the floor. Locate away from windows, vents, and other sources of draft. If possible, do not mount on an external wall, as this might cause inaccurate temperature readings.

5. Mount the backplate onto the wall using the screws provided.

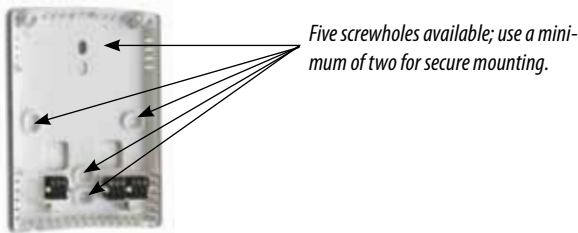

6. Wire the backplate.

Current Output (2-Wire, 4-20mA)

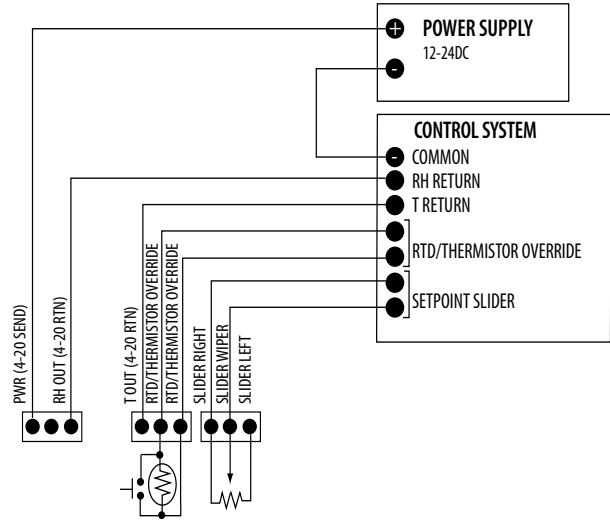

Voltage Output (3-Wire, 0-10V)

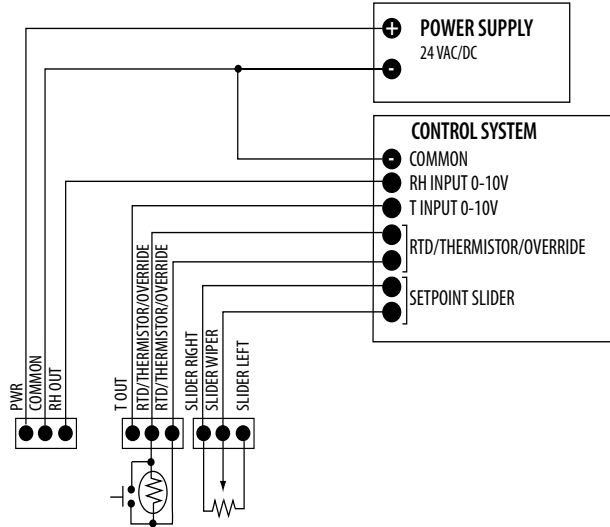

7. Install the sensor onto the backplate and use the switch to select voltage or current output. Output selection must be correct before applying power to the sensor.

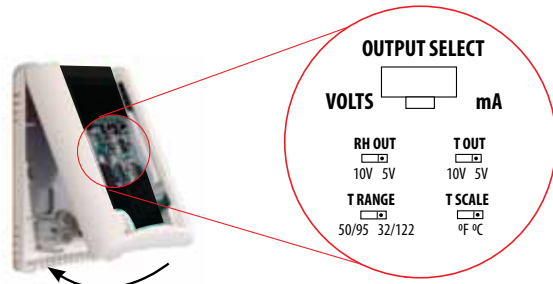

8. When the installation is complete, replace the cover and snap it into position.

